



G100

**IDEAL UNIT FOR HANDLING
PEANUTS IN THE SHELL
AND OTHER LIGHTWEIGHT
MATERIALS**

BUCKET ELEVATORS

*up to 12,000 ft³/h
(146 m³/h)
9,600 BPH*

SPECIFICATIONS

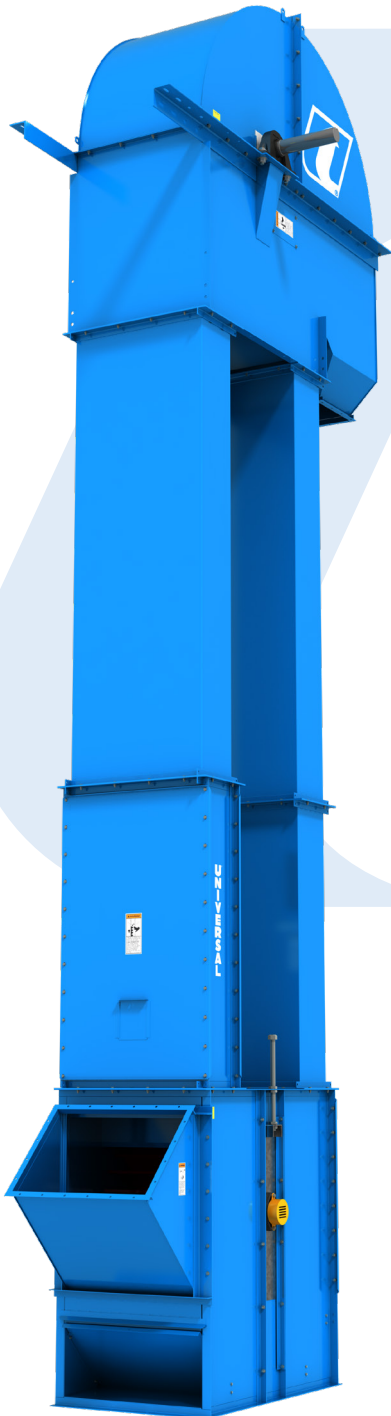

Model	G100
Capacity - Free Flowing Material @ 110% Waterline Bucket Fill	9,600 BPH 12,000 ft ³ /hr 146 m ³ /hr
Short TPH @ 15 lbs/Ft. ³	90
MTPH @ 15 lbs/Ft. ³	82
Short TPH @ 18 lbs/Ft. ³	108
MTPH @ 18 lbs/Ft. ³	98
Short TPH @ 22 lbs/Ft. ³	132
MTPH @ 22 lbs/Ft. ³	120
Belt Speed FPM	335 (1.7m/s)
Head Shaft RPM	42
Bucket Spacing	10" (254mm) Staggered
Head Casing	7 Ga.
Head Shaft Bearings	Sealed Pillow Block Ball Bearing Optional Tapered Roller
Head Pulley	30" (762mm) Dia. w/ Vulcanized Rubber Lagging
Buckets	12" X 8" (304mm X 203mm) HDPE Double Row
Belting	26" (660.4mm) Wide PVC
Legging	12 Ga. Twin Leg Seam Welded Columns
Boot Casing	7 Ga.
Boot Shaft Bearings	Sealed Two Bolt Flange Ball Bearing
Boot Pulley	30" (762mm) Dia. Self-Cleaning Wing Pulley
Construction	Powder Coated Carbon, Galvanized, or Stainless Steel
Drive Package	Optional
Motor	Optional

*Units in Parenthesis are Metric (mm)

Model G100

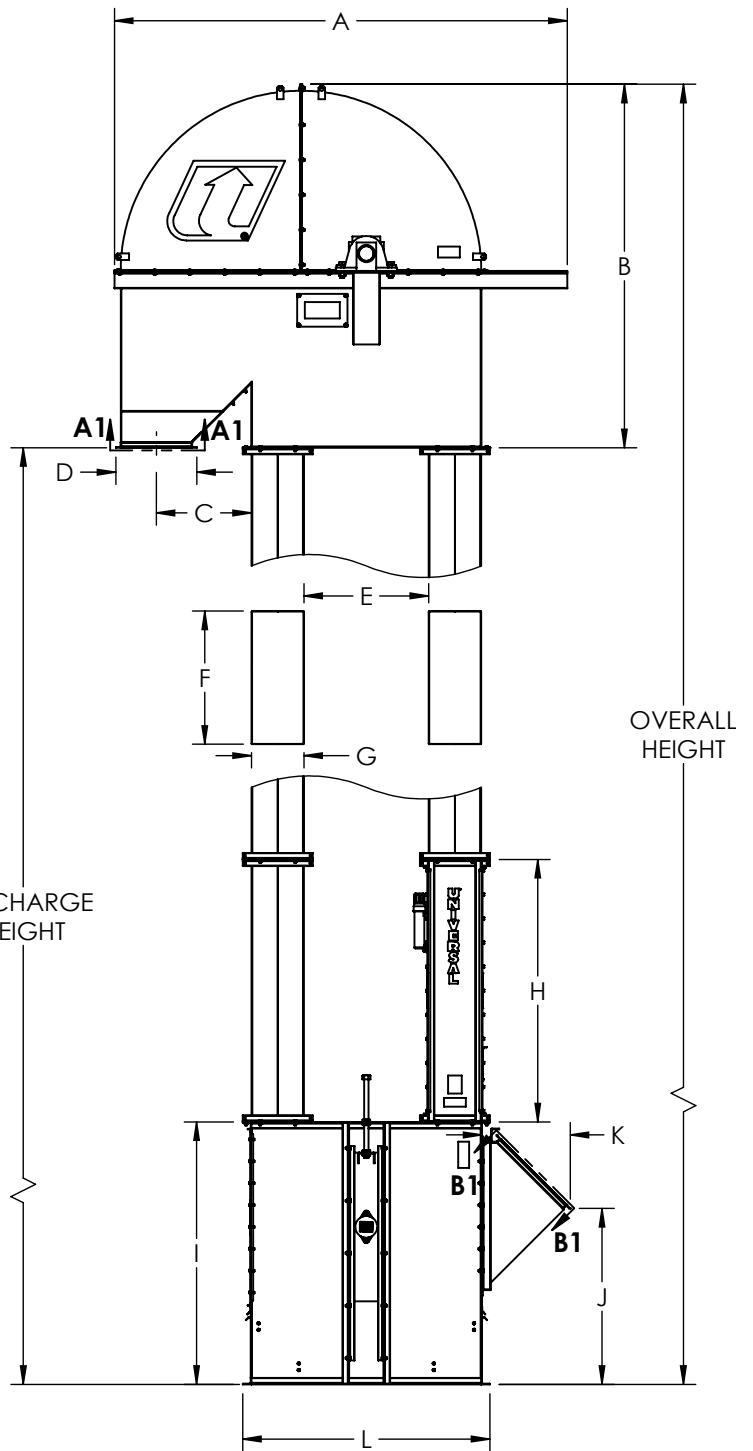
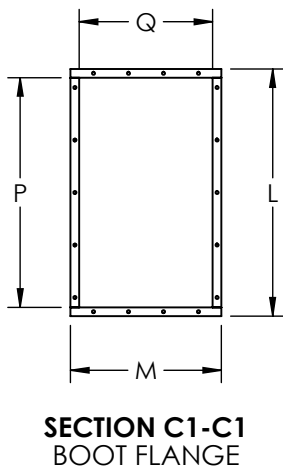
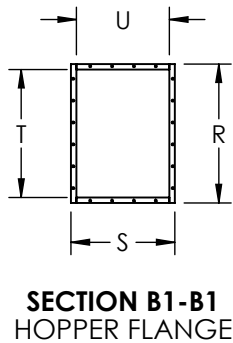
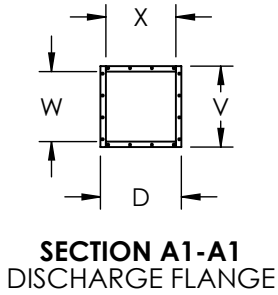
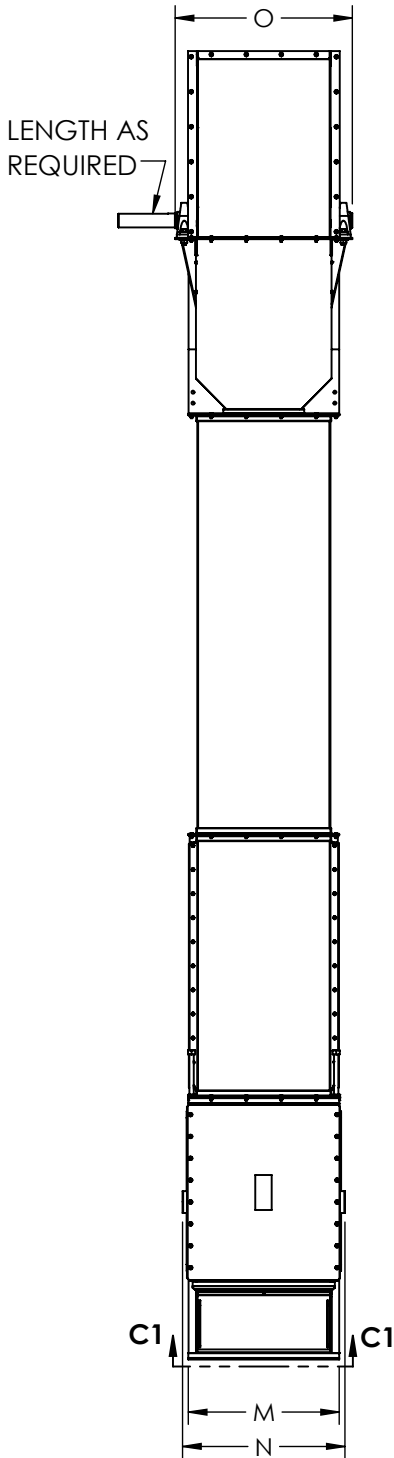

Unit	A	B	C	D	E	F	G	H	I	J	K	L	M	N	O	P	Q	R	S	T	U	V	W	X
in	103½	83	21¼	18½	28½	30½	12	60	60	40¼	20¼	56½	34½	37¼	40½	52½	30½	31¼	23¼	29¼	21¼	18½	16	16
mm	2629	2111	552	470	724	773	305	1524	1524	1022	512	1435	876	943	1029	1334	775	806	603	743	540	470	406	406

NOTE: Unit application, location and specifications determine the type, quantity and/or placement of electrical, electrical safety or other safety controls required. Whether these controls are supplied by Universal Industries or another supplier, all OSHA safety and health standards, the National Electrical Code and local codes must be met and followed. Because we constantly strive to provide the finest material handling equipment, establishing industry standards, specifications must remain subject to change without notice.